

# RAPTOR

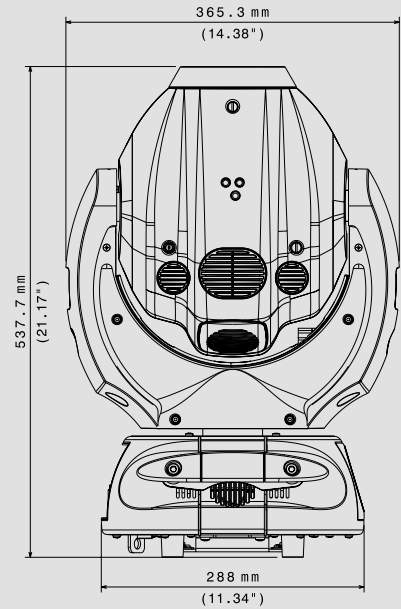

ULTRA BRIGHT, FAST MOVEMENT  
BEAM MOVING HEAD

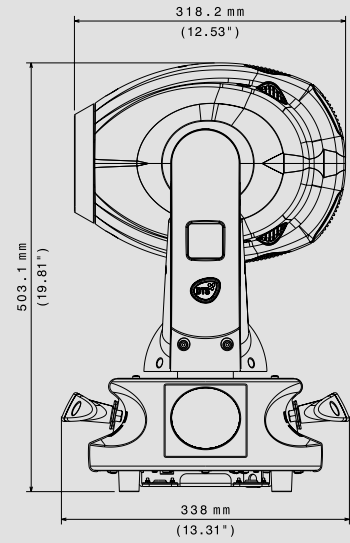

## FEATURES



## OPTIONALS

## CERTIFICATIONS



## CODE

03.MB005.EB.LFP



## TECHNICAL DATA

### OUTPUT

- Lamp: Osram Sirius HRI 330 W (16,500 Lumens)
  - Color temperature: 7500 K
  - CRI: 80
  - Average lamp life: 1,500 hours

### OPTICAL GROUP

- Beam opening: 3.4°
- 156,800 Lux @ 15 m
- 16-bit motorized linear focus
- Linear dimmer / shutter / ultra-fast strobe

### COLOR GENERATION

- 17-color wheel with linear selection for perfect 2-color beams

### DYNAMIC EFFECTS

- 17-gobo wheel
- 8-facet rotating prism

### FILTERS

- Smooth filter (eliminates the hot spot, evenly diffusing luminosity)
- Frost filter

### CONTROL

- LCD graphic display + 4 soft-keys (control / management of the main parameters)
- Controlled via DMX 512 and RDM standard digital communication protocols
- Internal operating system updatable via DTS dongle firmware uploader

### DMX

- 18 DMX channels (default)
- 20 DMX channels

### PAN & TILT

- 'FPR' system (DTS patent)
- Pan: limitless rotation, in both directions
- Tilt: 240°: 1.2 sec.
- Tri-phase stepper motor technology for ultra-fast silent movements
- 16-bit resolution
- Selectable speed ranges

### POWER SUPPLY

- Full-range 100-240Vac 50-60 Hz
- Power consumption: 450 W with PFC
- Power Factor: PF >0.90

### CONNECTIONS

- DMX: XLR 3-pole and 5-pole In / Out panel connectors
- Power supply: powerCON In / Out panel connectors

### INTERNAL SAFETY DEVICES

- Overvoltage and overtemperature circuits protection

### OPERATING TEMPERATURE

-10° / 40° C

### PHYSICAL

- IP20
- Weight: 17 Kg (37.5 lbs)
- Finishing: Black

## COLOR WHEEL



## ACCESSORIES INCLUDED

- 1 x PowerCON female cable connector (code 0520P014)
- 1 x XLR 5 Pins male cable connector (code 0508B148)
- 1 x XLR 5 Pins female cable connector (code 0508B147)
- 2 x Omega Bracket with "Fast Lock" connection 1/4 turn (code 02K00549)

## ACCESSORIES ON REQUEST

- Lamp Osram Sirius HRI 330 W (code 0505S037)
- Flightcase for 4 units (code 0521C059.1)
- Aliscaf clamp for tube diameter 48-51 mm - max. load. 200 Kg (code 0521A033)
- G-QUICK clamp Professional -max. load 100 Kg (code 0521A037)
- Outdoor DMX cable 2 x 0,25 mm<sup>2</sup> - Flame retardant (code 0509C158)
- Safety cable 5 x 600 mm - max capacity load 60 Kg (code 0521A038)
- DTS dongle firmware uploader (code 03.LA.206)

## PHOTOMETRIC DATA

|                                    | mt 5<br>ft 16.40 | mt 15<br>ft 49.21 | mt 25<br>ft 82.02 | mt 50<br>ft 164.04 | mt 100<br>ft 328.08 |
|------------------------------------|------------------|-------------------|-------------------|--------------------|---------------------|
| BEAM ANGLE 3.4°<br>lux center (lx) | 1411200          | 156800            | 56448             | 14112              | 3528                |
| foot candles (fc)                  | 131152           | 14572             | 5246              | 1312               | 328                 |
| diameter (cm)                      | 30               | 89                | 148               | 297                | 594                 |
| diameter (ft)                      | 0.97             | 2.92              | 4.87              | 9.74               | 19.47               |

## FIXED GOBO WHEEL

